

CARA

N208W/P SPECIFICATIONS

UNDERMOUNT BASIN

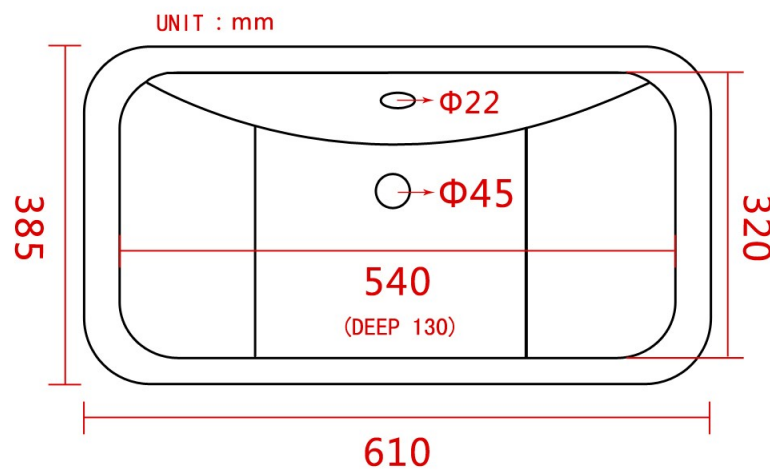

610 X 385 X 190 mm (total height 190)

FEATURES

Type	Undermount
Recommended Use	Domestic or Commercial
Colour	White
Waste	Pop up Waste Included (Chrome)
Tap Holes	N.A.
Overflow	Yes
Set Out	Refer to installation instructions
Fixing System	Glued in place
Material	Vitreous China
Weight	22 Kg
Australian Standards	AS/NZS1730



Disclaimer:

Products in this specification manual must by regulation be installed by licensed and registered trade people. Under our commitment to product development and improvement, we may change product specifications and dimension or delete models from the range without prior notification. Dimensions and set-outs listed are correct at time of publication and could contain dimensions which are approximate due to tolerances in manufacturing processes. It is important that you thoroughly review the product and check specifications and dimensions prior to surface preparation, cut-out and installation.



UNDERMOUNT BASIN



OUR WARRANTY TERMS

Definitions and Interpretation

In these terms and conditions of warranty:

“You” means the purchaser or customer acquiring the Goods and “Your” means belonging to you.

“We” and “Us” means Award Brands Pty Ltd. as the manufacturer of the Goods and “Our” means belonging to Us. “Goods” means the goods You claim to be defective.

ACL Guarantees and Our Warranty

Nothing in this warranty is intended to exclude, restrict or modify rights granted to You under the Australian Consumer Law or any other rights or remedies under any other laws relating to the Goods. The rights granted by this warranty are separate and in addition to the rights granted to You under the Australian Consumer Law.

Proof Of Purchase Essential

You MUST present proof of purchase of the Goods to obtain warranty service.

Proof of purchase may consist of either a copy of the purchase receipt or a builder handover document.

Warranty

We warrant that the Goods are free from defects arising solely from faulty materials or workmanship in the Goods. A reference in the warranty period table above to a product or part is a reference to the period during which the product or part will be repaired, replaced or the defect otherwise resolved in accordance with these terms. A reference to labour means We will supply labour (in addition to any item or part as relevant) in order to rectify the defect where it arises during the relevant period.

Warranty Period

To claim the warranty, You must contact Us by telephone, email or mail during the warranty period set out in this document that relates to the Goods. The warranty will expire at the end of the stated period from the date of original purchase or builder handover in the case of new buildings. The warranty period will not be extended by warranty service given during the warranty period.

Claims Procedure

Uninstalled Goods should be returned to their place of purchase for inspection and appropriate action.

If Goods have been installed and a defect is claimed, We may arrange for a service call at the place of installation to inspect or correct any defect. If the defect is found to have been caused by any reason that is not Our fault, We may charge You a service fee and We will not be liable for the defect.

Warranty service will only be provided during normal business hours and may be carried out by Us or Our agent. A service fee may also be charged where We or Our agent attend an agreed appointment time with You for inspection or repair but You do not attend.

To the extent permitted by law, We may at our option honour this warranty by replacement of Goods or parts of Goods, repair, refund, by compensating you for any loss in value of the Goods due to defect or by paying to you the cost of repair or replacement.

Warranty Not Transferable

The warranty is provided by Us as manufacturer to You as the consumer. It cannot be transferred or assigned to any other person.

Exclusions

Except as expressly stated otherwise or required by law, We exclude all undertakings, inducements, representations (whether express, implied, statutory or otherwise) relating in any way to the Goods or these conditions. The Warranty is only provided for the normal use of the Goods.

Without limiting the generality of the above, the Warranty will not cover each of the following:

- Defects and / or damage where adequate proof of purchase is unable to be provided.
- Damage arising solely from the installation of Goods that are obviously defective at the time of installation (i.e. where they should not have been installed due to obvious defect);
- Damage caused by accident, maltreatment, unusual stress or strain, harsh or adverse conditions, water pressure or temperatures that exceed stated limitations or that are generally excessive, neglect (including failure to follow recommended cleaning and maintenance instructions) or use of chemical cleaning products (including products containing high levels of chlorine) unless otherwise recommended.
- Damage caused by improper use, improper or poor installation.
- Damage resulting from installation or repairs by an unlicensed plumber.
- Failure to install Goods in accordance with Our instructions and specifications, public authority regulations or other National or State standards which govern water supply, sewerage and plumbing requirements of the location in which the Goods will be installed.
- Damage caused by isolating stop taps that are not fitted as stated in Our installation instructions.
- Damage caused by fitting of other devices to the outlet of tapware (e.g. Water filters).
- Damage or loss that results only because of:
 - i. a cause independent of human control that occurs after the Goods leave Our control;
 - ii. an act, default or omission of, or any representation made by, any person (other than Us or Our employee or agent); or
 - iii. the fact that the price charged by the supplier was higher than Our recommended retail price, or the average retail price, for the Goods.

Where Goods are coupled with a product not made by Us, Our warranty is limited only to Our Goods. Use of replacement parts or the attachment of accessories to Goods will void the warranty unless the parts or attachments used are genuine or approved by Us.

You are responsible for proving that Goods are / were defective and that any defect or loss was not caused by reason of any matter excluded in these conditions.

Consequential Loss

Subject always to rights You have under the Australian Consumer Law, and to the extent otherwise permitted by law, We will not be liable for any loss or damage to floor coverings, walls, fixtures, furnishings, or any other consequential loss caused by a defect in the Goods. For the avoidance of doubt, the exclusion of consequential loss applies only to loss occurred outside of the guarantees provided by the terms of the Australian Consumer Law.

PRODUCT CARE & MAINTENANCE

In order to preserve appearance with minimum effort, we offer the following advice. These easy care recommendations are intended to assist you, our customer. They are based on our experience and judgement but must not be regarded as amounting to a legal warranty or liability on our part.

Vitreous China

Use a mild household detergent, warm soapy water or cream cleaners and clean with a soft cloth.

Toilet Seats/Plastic Cisterns

The best method of maintaining the finish while ensuring the cleanliness of toilet seats is simply to wipe over with soapy water and a clean, soft cloth. It is important that no abrasive cleaners or wax-based creams are used as this can result in a build-up of deposits/scratches that will detract from the appearance.

Scratches

Avoid contact with hard, sharp objects. Should scratches occur on plastic products, fine marks can be removed using a cutting compound normally used for car re-treatment or Brasso, followed by buffing with a car polish and a clean, soft cloth.

Chemical Attack

Plastic products are resistant to most household products, but are not absolutely stain proof. Spills of some products such as hair lacquer, after shave lotion, nail polish and remover, mineral turpentine, white spirit, kerosene, aerosol propellants and insecticides should be removed immediately by washing the product. To restore toilet seat surface if marked, treat as for scratches.

Discolouration

Products such as hair dye, bleaches, boot polish and the like will discolour the surface if not removed immediately. Provided the discolouration is not severe, restore the surface as described for scratches.

Burns

Avoid placing hot objects, such as hair straighteners, curling tongs or lit cigarettes on any plastic surface as these will cause discolouration and marking. Should slight accidental damage occur, it may be possible to remove marks as for scratches.

Flushing

Flushing cleaners or chemical additives should NOT be used inside the cistern. All warranties will be void if such products are used with our products.

WARRANTY

Range	Warranty	Comments
Basins & Vessels	5/1 Years	5 year replacement product;

This Warranty is provided by:
Award Brands
63-69 Pound Road West
Dandenong South, Victoria 3175
Phone: 1800 425 563

